



# Introduction to ASX Derivatives Clearing System Open Interface V1.4.4



## Table of Contents

<b>1. INTRODUCTION .....</b>	<b>3</b>
1.1. BACKGROUND.....	3
1.2. ACCESS TO DCS .....	3
<b>2. SYSTEM CONFIGURATION .....</b>	<b>4</b>
2.1. GENERIC ASX DCS CONFIGURATION .....	4
2.2. EXAMPLE CONFIGURATION USING MCM .....	5
<b>3. GLOSSARY .....</b>	<b>6</b>

## **1. Introduction**

### **1.1. Background**

Derivatives Clearing System (DCS) is a clearing system for ASX Clear Pty Limited. DCS is a client-server design that relies on the deployment of ASX supplied Participant Messaging Module (PMOM) software to a Participant managed server. The PMOM ensures a reliable store and forward mechanism for messages between the Participant and ASXCL. It also maintains a copy of the Participants DCS data on a local database on the Participant side. This design permits extensive local activity by the Participant to manage accounts and positions, even if the main DCS server at ASX is offline or unreachable.

DCS does not provide client accounting services or production of client reports and contract notes. Participants can access the DCS local database to extract relevant information for input into their own client accounting back office systems.

### **1.2. Access to DCS**

Network access to DCS is provided over ASX Net. A requirement of ASX Net is that an ASX managed communications gateway be installed on the Participant side.

Application access to DCS is provided via PMOM. PMOM is installed transparently as part of the installation of MCM or any other vendor offering. It must be installed on a Windows server located on the Participants premises.

The PMOM provides a mechanism for participants to receive derivatives trade messages, margin information and other market messages. It is also used to send and receive messages allocating trades, giving and taking up positions and exercising positions etc.

Participants may choose to use ASX supplied Member Clearing Module (MCM) or develop/acquire their own client side clearing system using the DCS Open Interface (DCS OI). The DCS OI provides an interface into the PMOM which in turn communicates with the DCS server at ASX.

If MCM is chosen, then a participant system may interface to MCM via read only access to the MCM database or with transactional capability via a stored procedure interface to the MCM database called the Extended Interface Functionality (EIF).

## 2. System Configuration

### 2.1. Generic ASX DCS Configuration

The diagram below shows conceptually how connectivity to DCS is established between ASX and a single participant site.

The first requirement is the establishment of network connectivity to the ASX. This is achieved via an ASX Net connection (note, for the test bed an internet VPN option is available). An ASX Net connection requires that an ASX managed communications gateway be deployed at the participant site. This gateway is sometimes referred to as DCS Gateway and it is different to the server that hosts PMOM.

The second requirement is that a participant must install PMOM on a Windows server machine that they manage. The PMOM software is installed as part of the installation of MCM as part of any vendor product installation. This server must have visibility to the ASX Net DCS gateway.

PMOM exposes an OI that can be used by an accredited system to communicate with DCS.

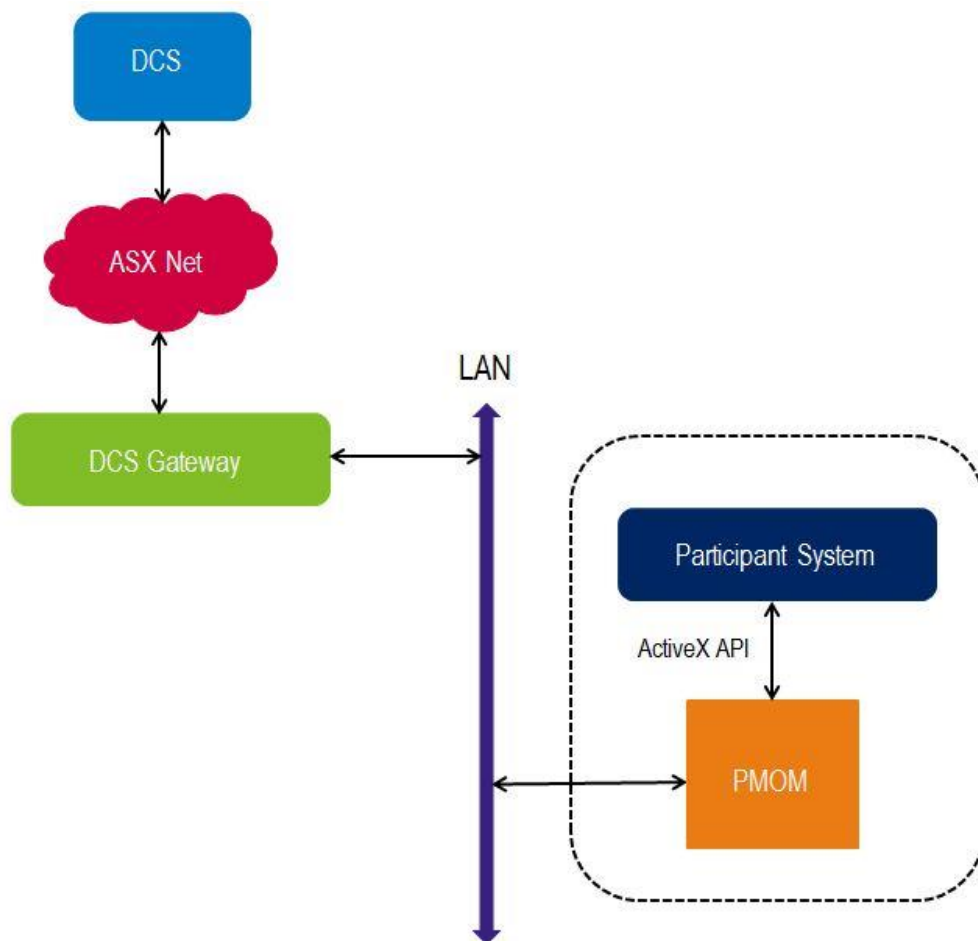

## 2.2. Example Configuration using MCM

The diagram below shows a potential configuration based on the ASX supplied MCM product.

MCM follows a client server model whereby the MCM Server communicates with the DCS OI, and the MCM Clients (deployed on the user desktop) communicate with the MCM Server.

In conjunction with using MCM, a participant may optionally interface their back office system with MCM in one or both of the following ways:

- Via the MCM EIF – This is a stored procedure interface that allows participants to initiate all common transactions directly from their own system. This is simpler than developing directly to the DCS OI. Refer to the *Derivatives Clearing System Open Interface V1.4.5 Extended Interface Functionality - Technical Overview Guide* for more information.
- Via direct read only access to the MCM server – Participants are free to extract data from the MCM database.

MCM requires an MS SQL Server 2008 (or higher) database. The database can be located on the same server as the MCM software or a dedicated database server.

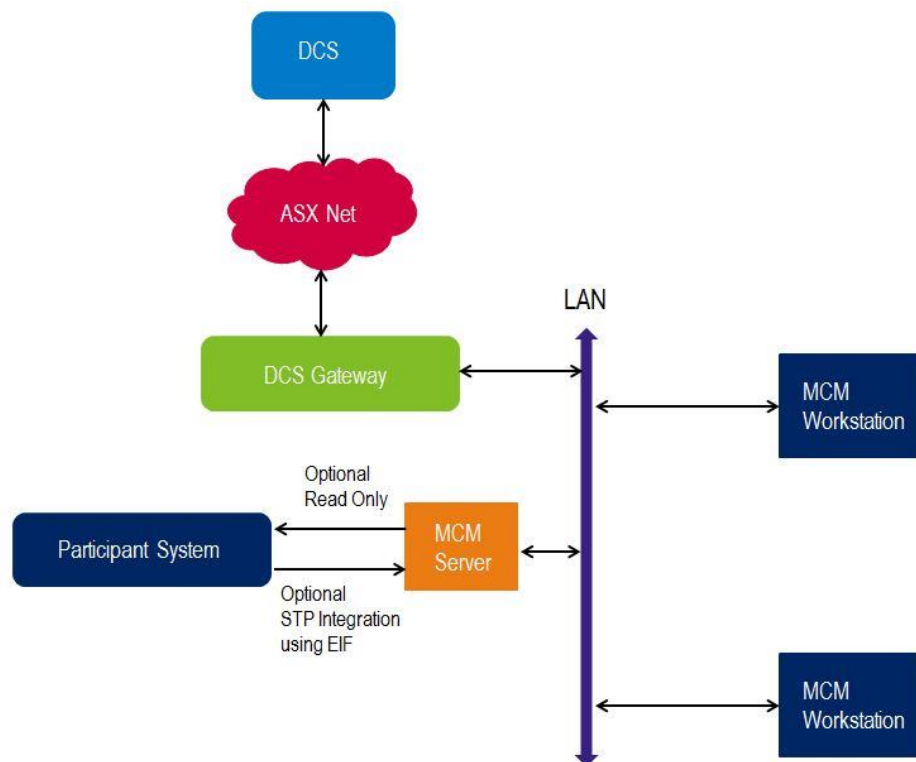

### 3. Glossary

Term	Definition
ASX Net	ASX Net is a low latency fibre network connection used for connecting to ASX Trade. It delivers distributed network connection latency of approximately 200 microseconds in the Sydney Central Business District (CBD). The point-to-point Ethernet connections enable fast access to a wide range of financial markets and third-party products and services, without the cost and complexity of duplicating network infrastructure.
ASX Clear (Derivatives) (ASXCL)	ASX's clearing business that clears ASX Trade derivatives products.
Derivatives Clearing System (DCS)	DCS is a client-server design using intelligent PC-based workstations for clearing participant access, with a local database attached to the workstation. This permits extensive local activity by the clearing participant to manage accounts and positions. DCS uses a reliable store and forward mechanism for messages between the participant and the Clearing House.
Extended Interface Functionality (EIF)	The EIF provides a mechanism for clearing participants and third-party vendors to interface to MCM in addition to the current API.
Member Clearing Module (MCM)	The ASX supplied DCS client. Participants may use MCM or one of the accredited systems supplied by vendors.
Participant Messaging Module (PMOM)	The mandatory client side component that manages messaging to DCS and exposes the ActiveX interface.
Straight Through Processing (STP)	STP with EIF allows MCM transactions to be initiated from the participants back office system without the need for human intervention.

#### Disclaimer

This document provides general information only and may be subject to change at any time without notice. ASX Limited (ABN 98 008 624 691) and its related bodies corporate ("ASX") makes no representation or warranty with respect to the accuracy, reliability or completeness of this information. To the extent permitted by law, ASX and its employees, officers and contractors shall not be liable for any loss or damage arising in any way, including by way of negligence, from or in connection with any information provided or omitted, or from anyone acting or refraining to act in reliance on this information. The information in this document is not a substitute for any relevant operating rules, and in the event of any inconsistency between this document and the operating rules, the operating rules prevail to the extent of the inconsistency.

#### ASX Trademarks

The trademarks listed below are trademarks of ASX. Where a mark is indicated as registered it is registered in Australia and may also be registered in other countries. Nothing contained in this document should be construed as being any licence or right to use of any trademark contained within the document.

ASX®